

-	10ULL97	N/A	INIT RELEASE	JRO	N/A	N/A
---	---------	-----	--------------	-----	-----	-----

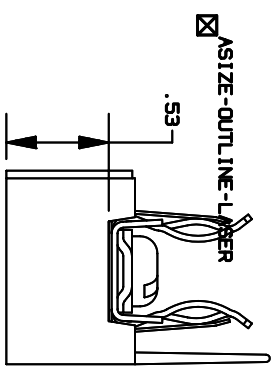
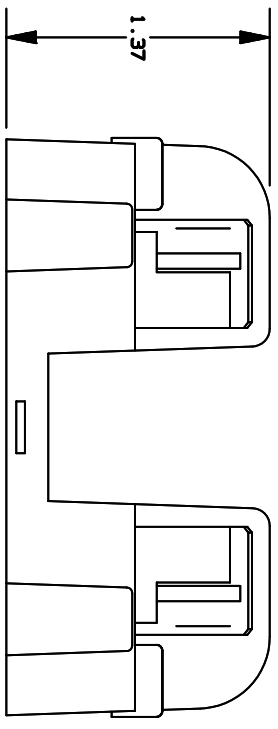
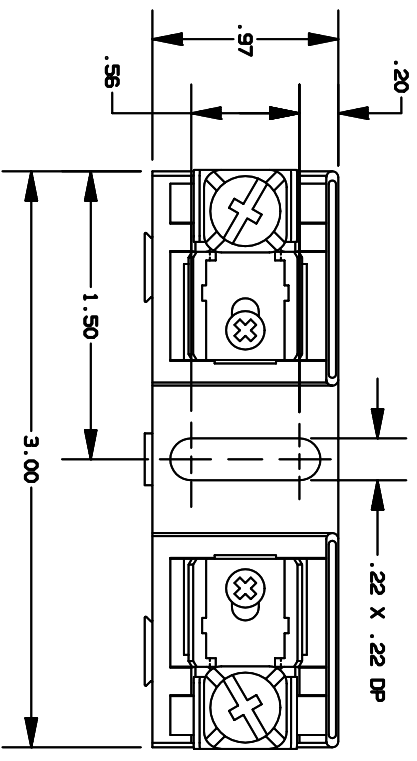

NOTE:

1. TOLERANCES  $\pm$ .015 UNLESS OTHERWISE SPECIFIED.
2. MATERIAL COMPOSITION AND RATING THERMOPLASTIC-125°C RTI.

P/N	CONN TYPE	RMS SYM RATING	TORQUE (IN-LBS)	WIRE		U/L		CSA REPORT NO.
				°C	TYPE	FILE NO.	GUIDE NO.	
70325	PRESSURE	200K	20	60/75	CU ONLY	E52283	12LT2	LR32169

FUSE BLOCK, 750V-30A ADDER

700289