

-	10ULL97	N/A	INIT RELEASE	JRD	N/A	N/A
---	---------	-----	--------------	-----	-----	-----

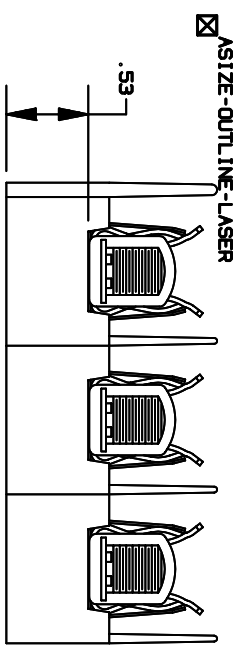
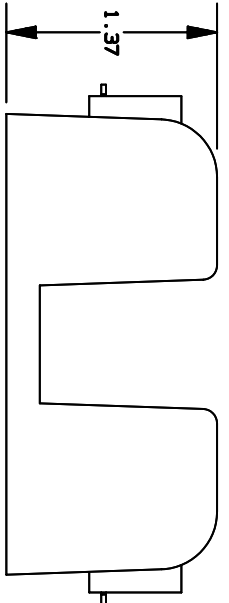
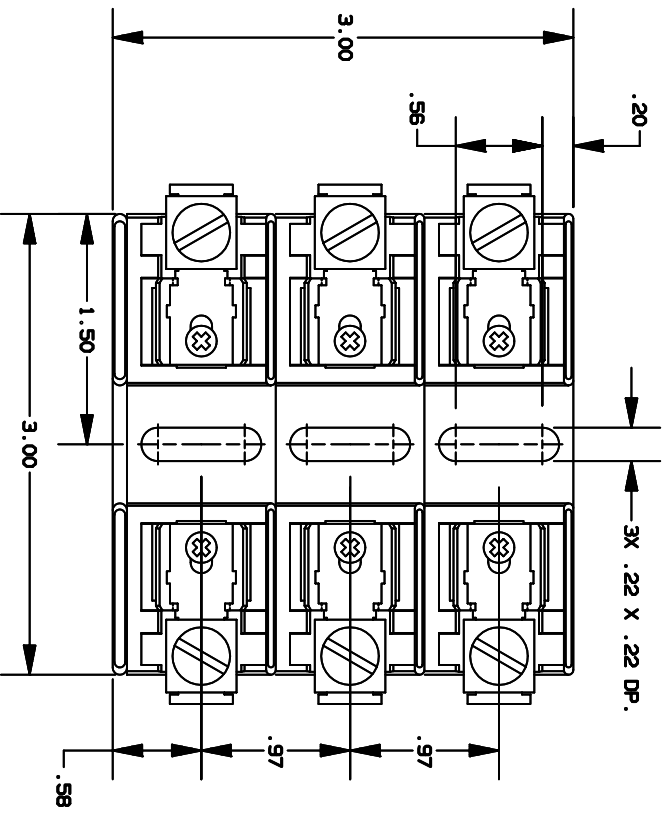

NOTE:

1. TOLERANCES \pm .015 UNLESS OTHERWISE SPECIFIED.
2. MATERIAL COMPOSITION AND RATING THERMOPLASTIC-125°C RTI.

P/N	CONN TYPE	RMS SYM RATING	TORQUE (IN-LBS)	WIRE		U/L	CSA	
				°C	TYPE			FILE NO.
70358	BDX	200K	35	60/75	CU ONLY	ES2283	1ZLT2	LR32169

FUSE BLOCK, 750V-30A 3 POLE

700296