

750V DC

SQUARE-BODY FUSES/SPECIAL PURPOSE

SIZE: 121



Ratings

- 200 to 250 Amps
- 750vdc at 100kA
L/R=100mSec
- 900vdc at 100kA
L/R=40mSec

Features/Benefits

- **Blown Fuse** indicator
- **Square** ceramic body
- **Full range** D.C. operation
- Bladed and tapped versions standard

➤ Dimensions

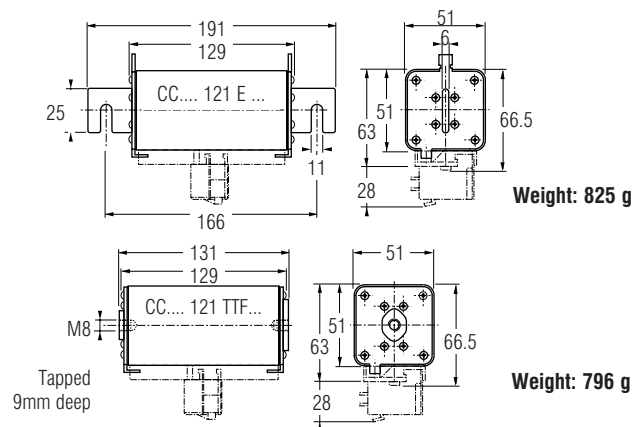

APPLICATIONS DATA

SIZE	CURRENT RATING I_n (A)	INTERRUPTING RATING	MAXIMUM I^2t @900V=L/R 40ms		WATTS LOSS		CATALOG NUMBER (1)	REF. NUMBER
			$I_p=10I_n$	$I_p=50I_n$	$0.8 I_n$	I_n		
121	200	@ 750V DC 100kA L/R = 100ms	755000	150000	20.5	37.5	CC 7,5 gRC 121 EF 0200 CC 7,5 gRC 121 EF 0250	A086710 M085203
	250		1250000	250000	25.5	46.7		
	200	@900V DC 100kA L/R = 40ms	755000	150000	20.5	37.5	CC 7,5 gRC 121 TTF 0200 CC 7,5 gRC 121 TTF 0250	N085250 Q085252
	250		1250000	250000	25.5	46.7		

Microswitch: MC 3E 1-5N Ref. Number: D310020
Contact factory for holder

750V DC

SQUARE-BODY FUSES/SPECIAL PURPOSE

DC Voltage Capabilities vs. Time Constant

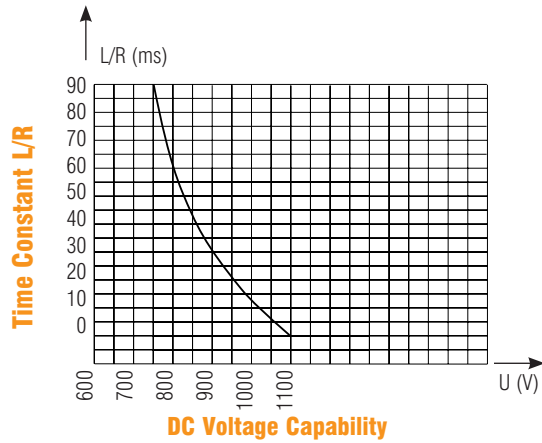

Above: Curve indicates maximum permissible value of time constant L/R as a function of DC working voltage.

Peak Arc Voltage vs. Working Voltage

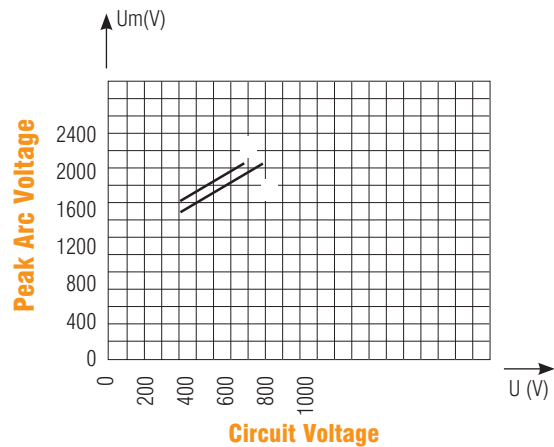

1-L/R = 100ms
2-L/R = 40ms

Melting Time-Current Data

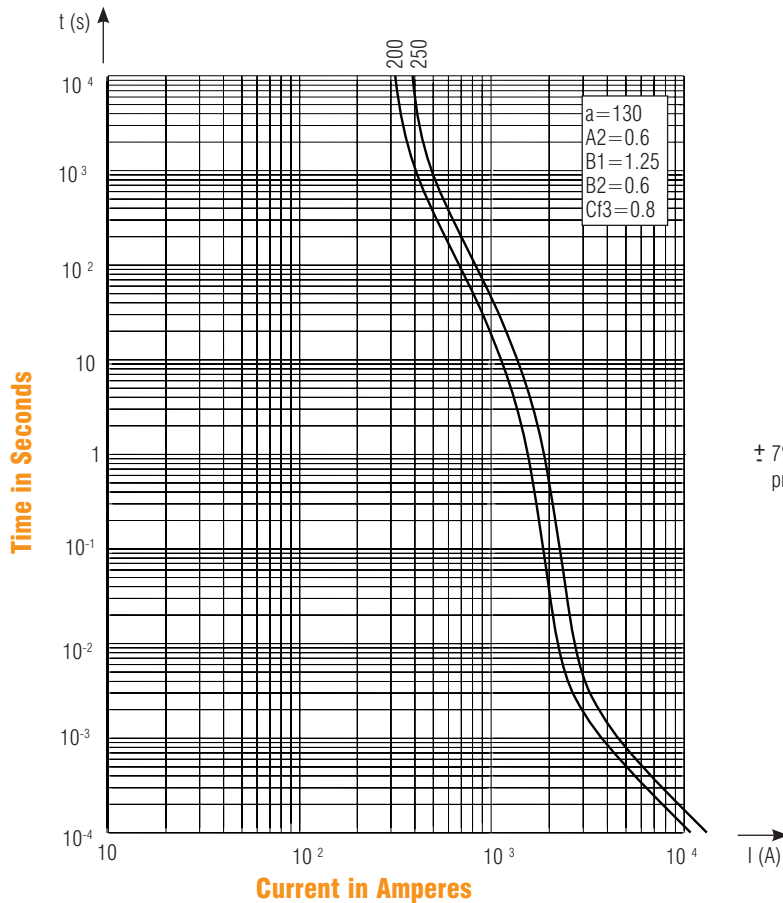

± 7% tolerance for mean pre-arcing (melting) current

Above: Curves indicate, for each rated current, pre-arcing (melting) time vs. R.M.S. pre-arcing (melting) current.