

DIRIS® A20

Product presentation



1. LCD display
2. Direct access key for instantaneous and max. currents values
3. Direct access key for voltages and frequency
4. Direct access key for active, reactive and apparent power (instantaneous and max. values) and power factor
5. Direct access key for energies

Using electrical parameters means using several analog or digital single-function products such as ammeters, voltmeters or watt meters.

DIRIS A20, with its four direct access keys and LCD displays, helps you use all the parameters in an LV installation.

These parameters can be centralized on a PC or PLC through an RS 485 link using JBUS/MODBUS protocol. The casing is designed so that the installer can easily fit the DIRIS A20 to the door of a cabinet. To facilitate and optimize the operator's work, the DIRIS A20 uses one of the most functional principles for integrating communications or metering.

Simply fit a module to the rear of the casing to add a function.

In addition, DIRIS A20 has a function for correcting connection errors.

DIRIS® A20



Select a DIRIS®

Auxiliary power supply U_s	Catalog number
110 ... 400 V AC / 120 ... 350 V DC (Product Limits)	4825 0A20
110 ... 240 V DC / 120 ... 250 V DC (UL Approved)	

Optional functions



Select a module

Description	Catalog number
Pulse output	4825 0080
1 configurable output impulses (type, weight and duration) for kWh+ and kvarh+	4825 0082
Communication	
RS 485 link with JBUS/MODBUS protocol (speed up to 38 400 bauds)	

Technical characteristics

Current measurement on inputs (TRMS)	
CT primary	9 999 A
CT secondary	5 A
Measurement range	0 ... 11 kA
Input consumption	0.6 VA
Measurement updating period	1 s
Accuracy	0.2 %
Sustained overload	6 A
Intermittent overload	10 In for 1 s
Impulse withstand voltage	4 kV
Voltage measurement (TRMS)	
Direct measurement between phases	50 ... 500 VAC
Input consumption	≤ 0.1 VA
Measurement updating period	1 s
Accuracy	0.2 %
Sustained overload	780 VAC
Power measurement	
Measurement updating period	1 s
Accuracy	0.5 %
Power factor measurement	
Measurement updating period	1 s
Accuracy	0.5 %
Frequency measurement	
Measurement range	45 ... 65 Hz
Measurement updating period	1 s
Accuracy	0.1 %

Energy accuracy	
Active (according to IEC 62053-22)	Class 0.5 S
Reactive (according to IEC 62053-23)	Class 2
Auxiliary power supply	
AC voltage	110 ... 400 VAC
AC tolerance	± 10 %
DC voltage	120 ... 350 VDC
DC tolerance	± 20 %
Frequency	50 / 60 Hz
Consumption	5 VA
Outputs (pulsed)	
Number of relays	1
Type	100 VDC - 0.5 A - 10 VA
Max. number of operations	≤ 10 ⁸
Communication	
Link	RS485
Type	2 ... 3 wires half duplex
Protocol	JBUS / MODBUS® in RTU mode
JBUS / MODBUS® speed	1400 ... 38400 bauds
Operating conditions	
Operating temperature	- 10 ... + 55 °C
Storage temperature	- 20 ... + 85 °C
Relative humidity	95 %

Dimensions (in / mm)

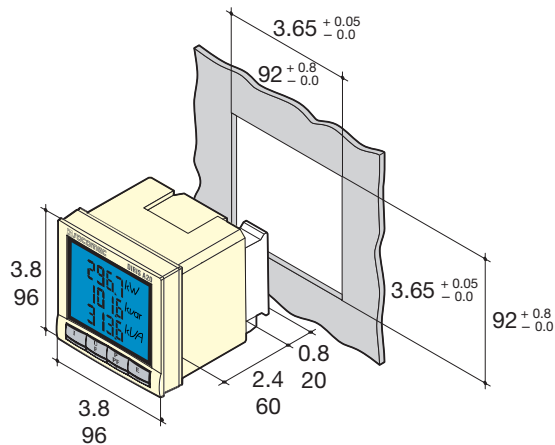

Type	panel mounting
Dimensions H x W x D	96 x 96 x 60 mm
Case protection rating	IP 30
Front protection rating	IP 52
Display type	LCD
Terminal block type	fixed and pull-out
Voltage and other connection section	0.2 ... 2.5 mm ²
Current connection section	0.5 ... 6 mm ²
Weight	400 g

Terminal blocks

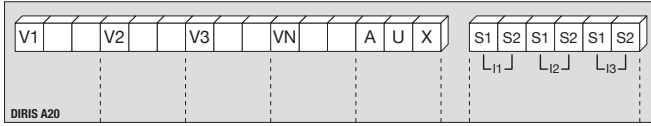

S1 - S2: current inputs
 AUX: auxiliary power supply Us
 V1, V2, V3 & VN: voltage inputs

Communication module

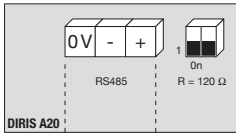

RS485 link
 R = 120 W: internal resistance for the RS485 link

Pulse output module

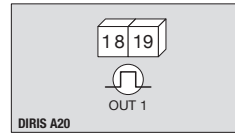

18 - 19: pulse output no. 1

Connections

Recommendation: when disconnecting the DIRIS, the secondaries of each current transformer must be short-circuited. This operation can be carried out automatically from a product in the SOCOMEC catalogue, PTI: please consult us.

Low voltage balanced network

- 3/4 wires with 1 CT

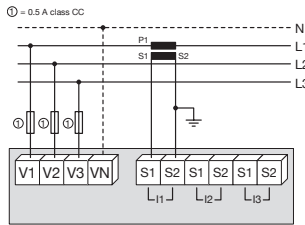

The use of 1 CT reduces by 0.5 % the accuracy of the phases whose current is determined by vector calculation.

- Single phase

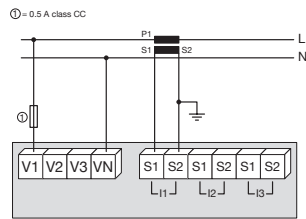

- Two phases

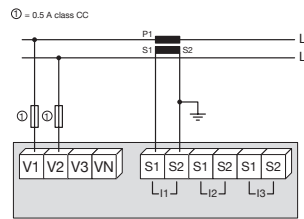

Low voltage unbalanced network

- 3/4 wires with 3 CTs

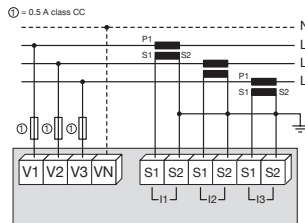

- 3 wires with 2 CTs

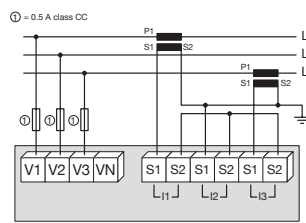

The use of 2 CTs reduces by 0.5 % the accuracy of the phase whose current is determined by vector calculation.

- 3 wires with 2 CTs

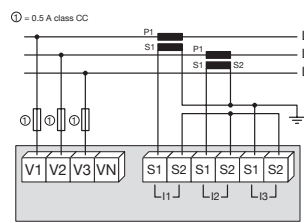

The use of 2 CTs reduces by 0.5 % the accuracy of the phase whose current is determined by vector calculation.

Other information

- Communication via RS485 link

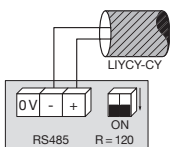

- AC & DC auxiliary power supply

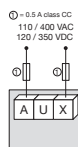

It is recommended that the auxiliary power supply be protected by the use of 0.5 A class CC fuses.