

TPMOV®

SURGE SUPPRESSION



THERMALLY PROTECTED MOV (TPMOV)

Ferraz Shawmut has developed the Thermally Protected MOV to eliminate common failure modes that have occurred in the field with standard Metal Oxide Varistors. Internally the TPMOV is comprised of a voltage clamping device and a disconnecting apparatus that monitors the status of the metal oxide disk making the TPMOV a fail-safe device. In the event of an overvoltage breakdown the metal oxide disk is securely disconnected from the system power by an arc shield. Upon failure the TPMOV is also equipped with a visual pin indicator as well as a normally open micro-switch providing remote indication if applicable.

The TPMOV is rated for 50kA - 8/20 μ s peak surge current and is available for maximum continuous operating voltages (MCOV) from 150V to 550VAC. No additional fusing or overcurrent protective device is required when using the TPMOV as compared to most MOV's on the market today.

Ratings

- 150V to 550VAC
- 100KA I.R.
- 50ka 8/20 μ s Peak Surge Current Rating
- Operating Temperature: -25C° to 60C°



Approvals

- UL 1449 2nd Edition Recognized
- RoHs Compliant

Features/Benefits

- High Energy Capacity
- Consistent footprint with 25–40mm MOV's
- Built-In Visual/Remote Indication
- Fail-Safe Operation

LAYOUT: The TPMOV footings are similar to that of equivalent voltage ratings of traditional 25 to 40mm MOV's. The TPMOV can be utilized on existing systems that utilize traditional MOV's without costly board redesigns.

*Refer to dimensional drawings on next page.

APPLICATION:

- Transient Voltage Surge Suppressors
- AC/DC Distribution Systems
- High Voltage Power Supplies
- Telecommunications Equipment
- Motor Control Systems
- Computer Related Products
- PLC Applications
- Power Transfer Switches
- Wave solderable

Part #	TPMOV voltage TM 1mA	
	min	max
150TPMOV	216	264
180TPMOV	259	317
250TPMOV	360	440
270TPMOV	389	475
320TPMOV	461	563
420TPMOV	605	739
510TPMOV	734	898
550TPMOV	792	968

DIMENSIONAL DRAWING OF TPMOV

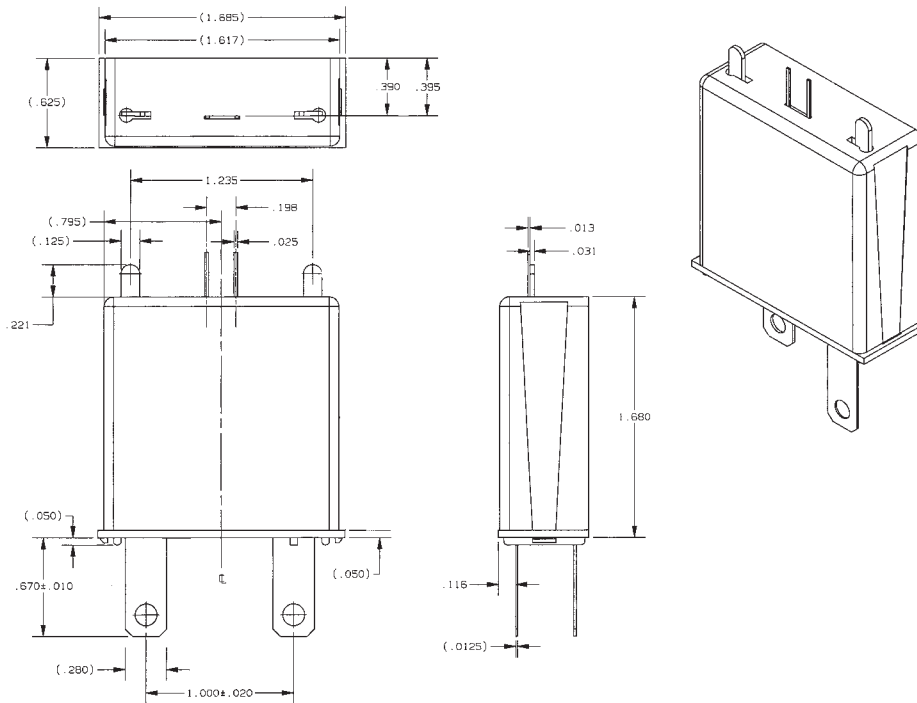

BOARD LAYOUT DIMENSIONS

