

Achieving Higher Short Circuit Current Ratings for Industrial Control Panels

Steve Hansen
Sr. Field Engineer

Introduction

Articles 409.110 and 670.3 in the National Electrical Code® require industrial control panels to be clearly marked with a Short Circuit Current Rating (SCCR). NEC® recognizes UL 508A, the Supplement SB as an approved method for determining panel SCCR. As of April 25, 2006, UL 508 Listed panels must be marked with SCCRs.

NEC® 110.10 requires that the “overcurrent protective devices [and] component SCCRs ...shall be so selected and coordinated to permit the circuit protective devices used to clear a fault to do so without extensive damage to the electrical components of the circuit.” In order to comply with NEC® 110.10, an industrial control panel must have an SCCR equal to or greater than the available fault current of the system where the panel is to be installed. An SCCR marking on a panel facilitates compliance with NEC® 110.10 during initial and future installations, should the panel need to be relocated.

UL 508A provides an analytical method for determining panel SCCR and allows an increase in the panel short circuit current rating if properly selected current-limiting fuses are installed in the panel. This issue of Tech Topics will explain how UL 508A Supplement SB is used to determine panel SCCR and how the use of type-tested components and current-limiting fuses can increase panel SCCR.

The following definitions will be helpful:

Available Fault Current – the maximum short circuit current that can flow in an unprotected circuit.

*Branch Circuit*¹ – the conductors and components following the last overcurrent protective device protecting a load.

Current-Limiting Fuse – a fuse which will limit both the magnitude and duration of current flow under short circuit current conditions.

*Feeder Circuit*¹ – the conductors and circuitry on the supply side of the branch circuit overcurrent protective device.

Interrupting Rating – the maximum current a fuse can safely interrupt.

Over-Current Protective Device (OCPD) – a fuse or a breaker used to protect downstream equipment.



Special points of interest:

The NEC® requires panel SCCR markings

Class J and Class CC fuses provide high panel SCCRs

Introduction continued from page 1

Peak Let Through Current (I_p) – The maximum instantaneous current passed by a current-limiting fuse when clearing a fault current of a specified magnitude.

Short Circuit Current Rating ¹ – The prospective symmetrical fault current at a nominal voltage to which an apparatus or system is able to be connected without sustaining damage exceeding the defined acceptance criteria.

¹ Glossary; UL Standard for Safety for Industrial Control Panels, UL508A. Revision through and including September 1, 2005.

Disclaimer

This paper has been written to demonstrate the concept of panel SCCR and to illustrate how high panel SCCRs can be obtained with current-limiting fuses. The author has attended the UL University training session on UL 508A, studied the standard in detail, and have firsthand field experience. The reader should understand that UL 508A has undergone numerous changes and will likely continue to evolve. At times there have been interpretation disagreements among experts on this subject. In no event will Ferraz Shawmut or the author of this paper be held liable for any direct or indirect damages arising from the use of the interpretations set forth in this paper.

“Industrial control panel SCCR can be determined by testing the assembled panel or by using an analytical method such as that described in Supplement SB of UL 508A.”

Methods For Determining Industrial Control Panel SCCR

There are two generally accepted approaches to determining panel SCCR. The first is to test the assembled panel to an existing standard with a third party witness, such as UL. Assuming the test results are acceptable, the panel is marked with the appropriate SCCR. This approach is common when the panel is relatively simple and panel volume is high.

The second method of determining the short circuit current rating of a panel is to use the requirements of UL 508A Supplement SB. Supplement SB allows the panel manufacturer to assign an SCCR to a panel without testing the assembled panel. This approach is particularly attractive for low volume or one-of-a-kind panels where the cost of testing the assembled panel would be prohibitive. The method set forth in Supplement SB is commonly referred to as the weakest link approach. In other words, the panel SCCR is limited to the SCCR of the lowest rated component or the lowest rated branch circuit protective device in the panel. If the panel contains a current-limiting feeder OCPD the current-limiting effects may be factored into the SCCR evaluation.

Supplement SB can be utilized to determine the SCCR of panels ranging from the simple to the complex. SB4.1.1 of UL 508A states, “The short circuit current rating of the overall industrial control panel shall be determined based upon:

- a) First, establishing the short circuit current ratings of individual power circuit components as specified in SB4.2;
- b) Second, modifying the available short circuit current within a portion of a circuit in the panel due to the presence of current limiting components as specified in SB4.3, when applicable; and
- c) Third, determining the overall panel short circuit current rating as specified in SB4.4.”

To illustrate this method consider the panel shown in Figure 1.

Step 1 — Determine SCCR of Power Circuit Components

Begin by determining the SCCR of each power component in each branch and feeder circuit contained within the panel. UL 508A requires that all power components (with the exception of power transformers, reactors, current transformers, dry-type capacitors, resistors, varistors, and voltmeters) have short circuit current ratings. Component SCCRs are established by UL during the Listing or Component Recognition process.

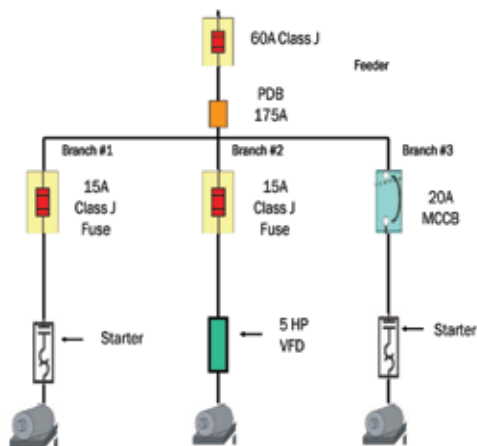

Figure 1: Control Panel

There are several ways to determine component SCCR. The SCCR may be marked on the component or on the instruction sheet packaged with it. Component SCCR values are often available on manufacturers' web sites. If the manufacturer has not provided an SCCR and the component is UL Listed or Component Recognized, the SCCR may be determined by referring to UL 508A Supplement SB, Table SB4.1. A copy of this table is shown on the top of page 8 as Table SB4.1.

Per UL 508A
“...establish the
short circuit
current rating
of individual
power circuit
components.”

The matrix shown in Figure 2 lists the components in the sample panel from Figure 1, the component SCCRs and the source of the rating information. Once the SCCR of the components in the power circuit have been established, the effects of current-limiting devices can be considered.

Circuit	Component	Component SCCR	Source of SCCR
Feeder	Fusible Switch	200kA	Product Marking
Feeder	Fuses, 60A	200kA	Product Marking
Feeder	PDB	10kA	UL508A Table SB4.1
Branch #1	Fuse Holder	200kA	Product Marking
Branch #1	Fuses, 15A	200kA	Product Marking
Branch #1	Starter	10kA	Product Marking
Branch #2	Fuse Holder	200kA	Product Marking
Branch #2	Fuses, 15A	200kA	Product Marking
Branch #2	VFD, 5HP	100kA	Instruction Sheet
Branch #3	MCCB, 20A	65kA	Product Marking
Branch #3	Starter	5kA	UL508A Table SB4.1

Figure 2: Component SCCRs of Control Panel of Figure 1

Step 2 – Consider the Effects of Current-Limiting Over-Current Protective Devices

Considering the effects of current-limiting devices in reducing available short circuit current allows for higher panel ratings. Quoting from UL 508A, SB4.1.1 b), this step consists of “...modifying the available short circuit current within a portion of a circuit in the panel due to the presence of current-limiting components as specified in SB4.3, when applicable...”

This means UL has determined that it is appropriate to apply a component in a circuit, provided the peak current passed by an upstream OCPD (I_p) does not exceed the component's SCCR. This approach is appropriate with three prerequisites. First, the upstream OCPD must be a UL Class CC, G, J, L, RK1, RK5, or T fuse or a listed circuit breaker marked “current-limiting”. Second, the current-limiting fuse or circuit breaker must be in the feeder circuit position (not the branch circuit) and must be located within the panel. Third, the I_p passed by the current-limiting OCPD in the feeder circuit must not be greater than the SCCR of the protected component.

To facilitate fuse selection, UL 508A contains Supplement SB, Table SB4.2 (Table 2, page 8) which shows fuse I_p as a function of available short circuit current. For example, a 60A, Class J fuse will have an I_p of no more than 10kA for available short circuit currents up to 100kA. Consider the panel shown in Figure 1 to illustrate this method.

The feeder circuit in the panel contains a Component Recognized power distribution block not marked with an SCCR. Using Table SB4.1 (top of page 8), the PDB is assigned an SCCR of 10kA. Class J, 60A fuses placed in the feeder circuit will limit I_p to 10kA at available currents up to 100kA, as shown by Table SB4.2 (bottom of page 8). Thus, the 10kA rated PDB is suitable, provided the available short circuit current on the line side of the feeder fuses is 100kA or less. The feeder circuit can now be assigned an SCCR of 100kA.

Continue with this approach by evaluating other components in the panel with low SCCRs. The motor starter in Branch #1 has a 10kA SCCR. Given that the available fault current on the line side of the feeder fuses is 100kA or less, the 10kA rated starter is appropriate for use. As with the feeder circuit, the 60A, Class J fuses have effectively increased the SCCR of Branch #1 to 100kA.

The 60A, Class J fuses in the feeder will not impact the SCCR of the VFD in Branch #2. The instruction sheet assigns the VFD a 100kA SCCR, provided the component is protected by Class J fuses rated 15A or less. The 15A, Class J branch circuit fuses shown in Figure 1 satisfy listing requirements.

Branch #3 contains a starter with no SCCR marked on the device or its instruction sheet. This starter is assigned an SCCR of 5kA, based upon Table SB4.1 (top of page 8). The Class J fuses in the feeder circuit do not limit I_p to 5kA under short circuit condition. The starter in branch #3 remains the weak link and limits the panel SCCR to 5kA.

UL 508A does not contain a table showing I_p values for circuit breakers, because the circuit breaker standard, UL 489, does not contain specific maximum allowable I_p values for current-limiting circuit breakers. Circuit breaker performance varies by manufacturer while by comparison, the UL 248 series of fuse standards specifies maximum acceptable I_p values for Class CC, G, J, L, RK1, RK5, and T fuses at available short circuit currents of 50kA, 100kA, and 200kA. Thus, if using current-limiting circuit breakers, one must refer to the I_p graphs published by the circuit breaker manufacturer.

“If the panel contains a current-limiting feeder circuit OCPD, the current-limiting effects of this device may be factored into the evaluation.”

Step 3 - Assigning Overall Panel SCCR

The final step is to assign an SCCR to the overall panel. This rating will be marked on the panel and will facilitate compliance with NEC® 110.10 and NEC® 409.110. Begin by adjusting the matrix developed in Step 1 to reflect the current-limiting effects evaluated in Step 2. The new matrix is shown below in Figure 3.

Circuit	Component	Component SCCR	Source of SCCR	Adjusted SCCR
Feeder	Fusible Switch	200kA	Product Marking	
Feeder	Fuses, 60A	200kA	Product Marking	
Feeder	PDB	10kA	UL508A Table SB4.1	100kA
Branch #1	Fusible Switch	200kA	Product Marking	
Branch #1	Fuses, 15A	200kA	Product Marking	
Branch #1	Starter	10kA	Product Marking	100kA
Branch #2	Fusible Switch	200kA	Product Marking	
Branch #2	Fuses, 15A	200kA	Product Marking	
Branch #2	VFD, 5HP	100kA	Instruction Sheet	
Branch #3	MCCB, 20A	65kA	Product Marking	No Change
Branch #3	Starter	5kA	UL508A Table SB4.1	No Change

Figure 3: Adjusted component SCCRs

Following the weakest link approach, identify the lowest component SCCR rating in the panel power circuits. In this example, the starter SCCR in Branch #3 is 5kA. Therefore, the short circuit current rating of this panel is 5kA.

Control Circuit SCCR

A low SCCR for the control circuit can limit panel SCCR. The control circuit SCCR is equal to the interrupting rating of the OCPD protecting the control circuit (SB3.2 of UL 508A). This potential weak link can be eliminated by protecting the control circuit with Class CC time-delay fuses, which allow a 200kA SCCR.

How Much SCCR Is Enough?

Panel SCCR must be greater than the available short circuit current at the point where the panel receives power. How much SCCR is enough? That will, of course, depend on the facility, the location in plant and the installation. Keep in mind that changes in the power system affect short circuit current levels. Panels located in one area of the plant may later move to another area, changing the available short circuit current. In today's industrial and commercial facilities a panel with a 10kA SCCR is just not adequate. As an example, a single 2500kVA transformer with a 480V secondary and a utility primary capability of 250MVA will have a secondary short circuit current (including motor contribution) approaching 60kA. A panel with a 100kA SCCR is suitable for virtually all industrial and commercial installations.

“Panel SCCR cannot be higher than the lowest branch circuit overcurrent protective device interrupting rating.”

“A 10kA SCCR is not adequate for many industrial and commercial applications.”

Strategies For Increasing Panel SCCR

The panel in Figure 4 demonstrates strategies for increasing panel SCCR, including:

- Upgrading to components with higher SCCRs
- Considering the use of type-tested components
- Taking advantage of the high degree of current-limitation provided by Class J time-delay and Class CC time-delay fuses to protect low rated components

“Increase panel SCCR by selecting components with a higher SCCR.”

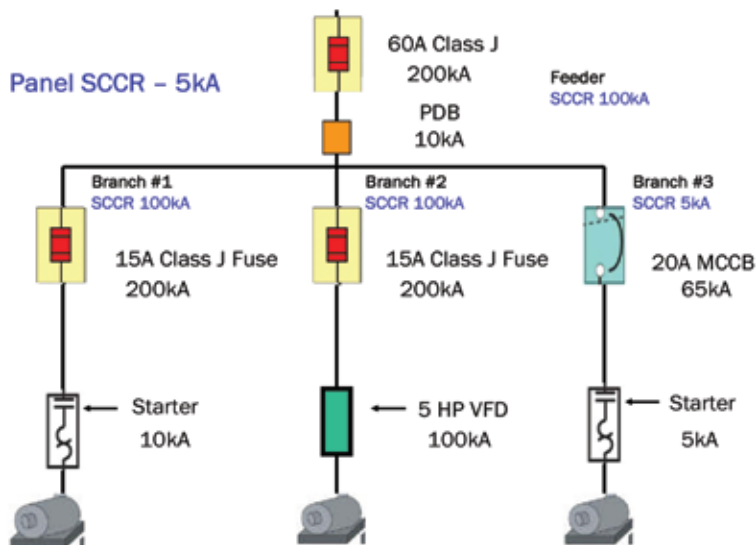

Figure 4: Panel shown with component SCCR adjusted for the current-limiting effects of the 60A Class J fuses in the feeder circuit

Upgrading Components Can Increase Panel SCCR

Consider the example panel in Figure 4, which shows component SCCR adjusted for the current-limiting effects of the feeder fuses. The starter in Branch #3 is the weakest link and limits the panel SCCR to 5kA. What happens if the starter in Branch #3 is upgraded to a starter marked with a 10kA SCCR? After adjusting for the I_p of the current-limiting feeder fuses, the new starter has a modified SCCR of 100kA. At this point, the 20A MCCB in Branch #3 is the weak link and limits the panel SCCR to 65kA.

Using High Fault Current Tested Components

The UL 508 Standard allows the component manufacturer to test components with specific OCPDs at higher current levels to establish what UL refers to as “high fault short circuit current ratings.” This process is called type-testing. Rather than use the minimum SCCR levels given by Table SB4.1 (top of page 8), the manufacturer may be contacted to determine whether higher ratings have been established for a specific component. Refer again to Figure 4. The starter manufacturer offers a comparable starter that has been successfully tested at 100kA with 15A Class CC fuses. Replacing the 5kA starter with the 100kA starter and the 20A MCCB with Class CC fuses rated 15A or less, the two weakest links in the original panel have been eliminated. The panel can now be labeled with a 100kA SCCR. If the fuseholder in which the class CC fuses are installed will accept fuses having a larger continuous current rating than the maximum rating proven by the type-testing, a label must be mounted next to the fuseholder specifying the current rating of the replacement fuses.

Increase Panel SCCR Using Class J or Class CC Fuses

Panel designers using RK5 fuses or OCPDs that are not current-limiting, as shown in Figure 5, may unnecessarily limit the panel SCCR and restrict the range of applications.

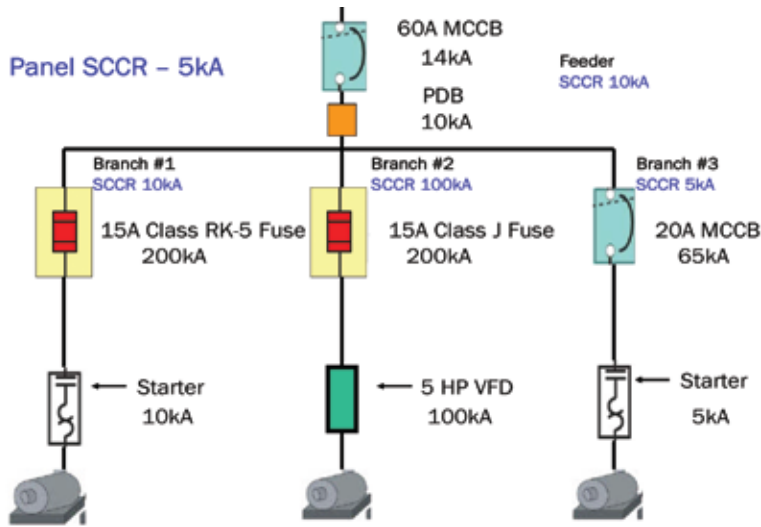

Figure 5: Panel with a low SCCR

Figure 6 illustrates the results possible with an all-fuse panel. Class J or Class CC time-delay fuses are chosen for their high degree of current-limitation. The result is a panel with a high SCCR, which is more likely to provide NEC® compliance, installation flexibility and enhanced safety.

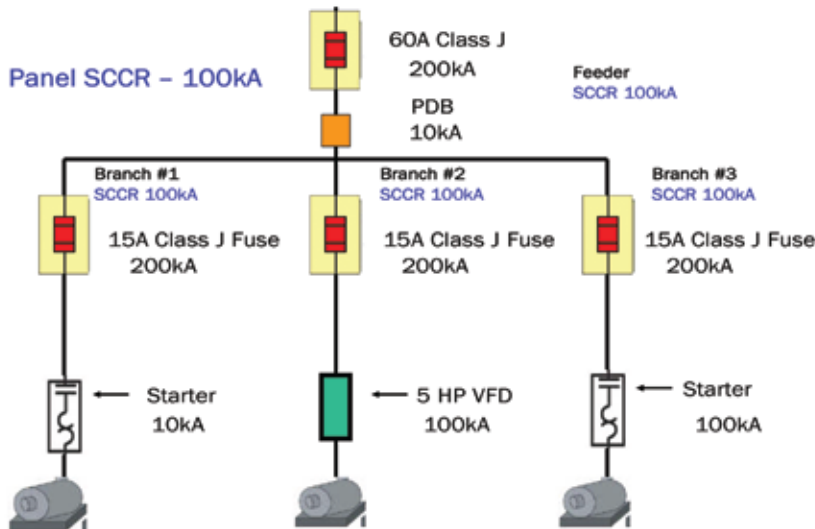

Figure 6: Panel with Class J fuses

“Increase panel SCCR with Class J time-delay or Class CC time-delay fuses.”

Table SB4.1 UL Standard for Safety for Industrial Control Panels, UL508A Supplement SB
Assumed maximum short circuit current rating for unmarked components
 Table SB4.1 effective April 25, 2006

Component	Short circuit current rating, kA
Bus bars	10
Circuit breaker (including GFCI type)	5
Current meters	a
Current shunt	10
Fuseholder	10
Industrial control equipment	
a. Auxiliary devices (overload relay)	5
b. Switches (other than mercury tube type)	5
c. Mercury tube switches	
Rated over 60 amperes or over 250 volts	5
Rated 250 volts or less, 60 amperes or less, and over 2 kVA	3.5
Rated 250 volts or less and 2 kVA or less	1
Motor controller rated in horsepower (kW)	
a. 0 - 50 (0 - 37.3)	5 ^c
b. 51 - 200 (38 - 149)	10 ^c
c. 201 - 400 (150 - 298)	18 ^c
d. 401 - 600 (299 - 447)	30 ^c
e. 601 - 900 (448 - 671)	42 ^c
f. 901 - 1500 (672 - 1193)	85 ^c
Meter socket base	10
Miniature or miscellaneous fuse	10 ^b
Receptacle (GFCI type)	2
Receptacle (other than GFCI type)	10
Supplementary protector	0.2
Switch unit	5
Terminal block or power distribution block	10
^a A short circuit current rating is not required when connected via a current transformer or current shunt. A directly connected current meter shall have a marked short circuit current rating. ^b The use of a miniature fuse is limited to 125-volt circuits. ^c Standard fault current rating for motor controller rated within specified horsepower range.	

Table SB4.2 UL Standard for Safety for Industrial Control Panels, UL508A Supplement SB
Peak let through currents, I_p, and clearing, I_t, for fuses
 Table SB4.2 effective April 25, 2006

Fuse Types	Fuse Rating Amperes	Between Threshold and 50kA		100 kA		200 kA							
		1 st x 10 ³	I _p x 10 ³	1 st x 10 ³	I _p x 10 ³	1 st x 10 ³	I _p x 10 ³						
Class CC	15	2	3	2	3	3	4						
	20	2	3	3	4	3	5						
	30	7	6	7	7.5	7	12						
Class G	15	-	-	3.8	4	-	-						
	20	-	-	5	5	-	-						
	30	-	-	7	7	-	-						
	60	-	-	25	10.5	-	-						
300 Volt Class T	30	3.5	5	3.5	7	3.5	9						
	60	15	7	15	9	15	12						
	100	40	9	40	12	40	12						
	200	150	13	150	16	150	20						
	400	500	22	550	28	550	35						
	600	1000	29	1000	37	1000	46						
	800	1500	37	1500	50	1500	65						
1200	3500	50	3500	65	4000	80							
Class J and 600 Volt Class T	30	7	6	7	7.5	7	12						
	60	30	8	30	10	30	16						
	100	60	12	80	14	80	20						
	200	200	16	300	20	300	30						
	400	1000	25	1100	30	1100	45						
	600	2500	35	2500	45	2500	70						
800	4000	50	4000	55	4000	75							
Class L	800	10000	80	10000	80	10000	80						
	1200	12000	80	12000	80	15000	120						
	1600	22000	100	22000	100	30000	150						
	2000	35000	110	35000	120	40000	165						
	2500	-	-	75000	165	75000	180						
	3000	-	-	100000	175	100000	200						
	4000	-	-	150000	220	150000	250						
	5000	-	-	350000	-	350000	300						
6000	-	-	350000	-	500000	350							
Class R		RK1	RK5	RK1	RK5	RK1	RK5	RK1	RK5	RK1	RK5		
	30	10	50	6	11	10	50	10	11	11	50	12	14
	60	200	200	10	20	40	200	12	21	50	200	16	26
	100	500	500	14	22	100	500	16	25	100	500	20	32
	200	1600	1600	18	32	400	1600	22	40	400	2000	30	50
	400	5000	5000	33	50	1200	5000	35	60	1600	6000	50	75
	600	10000	10000	43	65	3000	10000	50	80	4000	12000	70	100



For more information, visit our website at us.ferrazshawmut.com

374 Merrimac Street
 Newburyport, MA 01950
 T: 978-462-6662
 F: 978-462-0181

TF-SCN1-001 / Q2500 / 8.08 / STASSOC



©2006 Ferraz Shawmut All Rights Reserved.

Achieving High Industrial Control Panel Short Circuit Current Ratings